

General Purpose Clutches

FSA

Overrunning, Indexing Ball Bearing Supported, Sprag Clutches

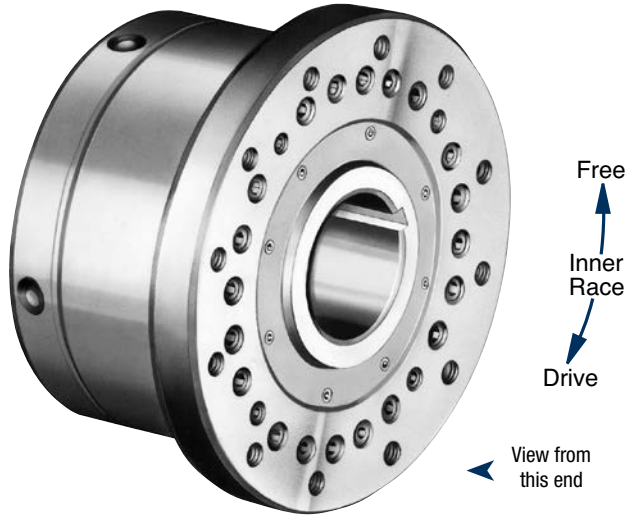

Right Hand rotation shown. (Left Hand opposite.)
Specify direction of rotation when ordering.

FSA model clutches are designed for low speed overrunning and indexing applications in the torque range from 38,000 to 500,000 lb.ft. FSA clutches are oil lubricated and equipped with lip-type seals.

Formchrome® sprags (used in model 1051 only) and “Free-action” retainers are incorporated for maximum performance and service life. These clutches mount on a through shaft, with the inner race driven by a key. They are designed with a special flange as the mounting surface for couplings for primary shaft to shaft inline applications. The ground O.D. of this flange is concentric with the bore. Tapped holes are provided for securing parts to the clutch. All new applications must be reviewed by Formsprag Application Engineering Department for correct bearing support. Refer to Shaft/Bore Tolerance chart for mounting data, page 126.

Standard keys are supplied by Formsprag at no additional charge.

Oil Lubricated Clutch

FSA-1051 through 5000 clutches are shipped from the factory with Mobil DTE Heavy Medium oil.

Grease Lubricated Clutch

FSA-1051 through 5000 clutches are shipped from the factory packed with Shell Alvania #1 grease.

For further information see *Installation and Maintenance Bulletin No. A-3032, P--222-20.*

Typical Mounting Arrangement

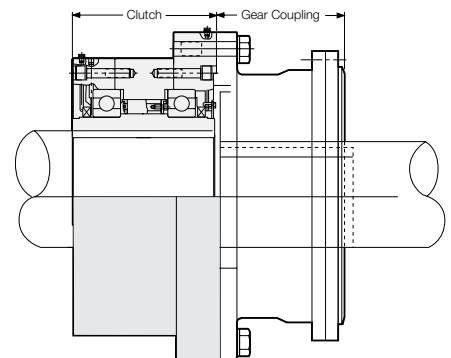

The Model FSA clutches must be axially restrained, see accessories page 120 for set collars, restraint keys and OSHA covers, etc. All fasteners are recommended to be grade 8 bolts.

Specifications

Size	Torque Capacity lb.ft. (Nm)	Overrunning Speed Max. RPM		Resistance after run-in lb.ft. (Nm)	Lubrication Oil qt (L)	Shipping Weight lb. (kg)
		Inner Race	Outer Race			
1051	38,000 (51680)	400	50	12.0 (16.3)	1.1 (1.07)	433 (196)
1250	47,000 (63920)	170	40	15.0 (203)	2.1 (2.0)	605 (274)
1300	69,000 (93840)	140	35	28 (38.0)	2.4 (2.28)	758 (344)
1375	110,000 (149600)	130	30	32 (43.4)	2.8 (2.66)	996 (452)
2000	200,000 (272000)	100	25	80 (108.5)	3.3 (3.1)	1797 (815)
2400	245,000 (333200)	85	20	100 (135.6)	3.9 (3.7)	2637 (1196)
3500	350,000 (476000)	80	20	120 (162.7)	12 (11.4)	5139 (2331)
5000	500,000 (680000)	75	20	125 (169.5)	11 (10.4)	5389 (2444)

Notes:

Check key and shaft stress before making final clutch selection since this may determine the maximum allowable drive torque capacity.

On Models 750 through 5000, Formsprag may elect to supply a stepped key in the event of keyseat distortion during heat treat of inner race.

Specify direction of rotation when ordering.

Bore sizes and keyseats**† inches (mm) (Metric bore also available)

Size	Bore Size	Keyseat	Bore Range	
			Min.	Max.
1051	5.000 to 6.000 (127.00 to 152.40)	1.250 x .63 (31.75 x 15.88)	4.937 (125.40)	7.000 (177.80)
	6.016 to 6.625 (152.81 to 168.28)	1.500 x .63 (38.10 x 15.88)		
	6.641 to 6.875 (168.68 to 174.63)	1.500 x .50 (38.10 x 12.70)		
	6.891 to 7.000 (175.03 to 177.80)	1.500 x .44 (38.10 x 11.10)		
	7.500 to 7.937 (190.50 to 201.60)	1.750 x .88 (44.45 x 22.22)		
1250	8.000 to 8.250 (203.20 to 209.55)	1.750 x .63 (44.45 x 15.87)	6.750 (171.45)	9.000 (228.60)
	8.312 to 9.000 (211.12 to 228.60)	1.500 x .50 (38.10 x 12.70)		
	8.000 to 9.250 (203.20 to 234.95)	1.750 x .88 (44.45 x 22.22)		
1300	9.312 to 10.000 (236.52 to 254.00)	1.500 x .50 (38.10 x 12.70)	7.937 (201.60)	10.000 (254.00)
	9.000 to 10.250 (228.60 to 260.35)	1.750 x .88 (44.45 x 22.22)		
1375	10.312 to 11.000 (261.92 to 279.40)	2.000 x .75 (50.80 x 19.05)	8.937 (227.00)	11.000 (279.40)
	11.000 to 12.000 (279.40 to 304.80)	1.750 x 1.25 (63.50 x 31.75)		
2000	12.063 to 13.250 (306.40 to 336.55)	2.500 x 1.00 (63.50 x 25.40)	10.937 (277.80)	13.250 (336.55)
	13.250 to 15.000 (336.55 to 381.00)	2.500 x 1.25 (63.50 x 31.75)		
2400	15.063 to 15.500 (382.60 to 393.70)	2.500 x 1.00 (63.50 x 25.40)	13.000 (330.20)	15.500 (393.70)
	13.500 to 13.750 (342.90 to 349.25)	2.500 x 1.25 (63.50 x 31.75)		
3500	14.000 to 18.000 (355.60 to 457.20)	3.000 x 1.50 (76.20 x 38.10)	13.437 (341.30)	20.000 (508.00)
	20.000	3.000 x 1.25 (76.20 x 31.75)		
	13.500 to 13.750 (342.90 to 349.25)	2.500 x 1.25 (63.50 x 31.75)		
5000	14.000 to 18.000 (355.60 to 457.20)	3.000 x 1.50 (76.20 x 38.10)	13.437 (341.30)	20.000 (508.00)
	20.000	3.000 x 1.25 (76.20 x 31.75)		
	13.500 to 13.750 (342.90 to 349.25)	2.500 x 1.25 (63.50 x 31.75)		

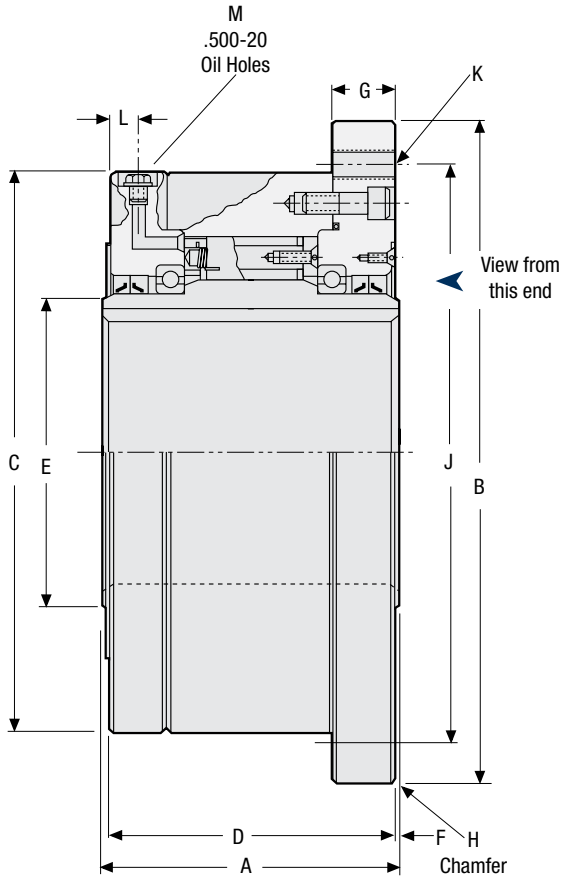

Dimensions inches (mm)

** For finished dimensions of keys supplied with the clutch, contact Formsprag.
† For Bore Sizes/Shaft Tolerances, see page 126.

Size	A	B	C	D	E	F	G	H	J	K			L	M
										Number	Thread	Depth		
1051	9.63 (244.47)	19.500/19.497 (495.30/495.22)	15.00 (381.00)	9.50 (241.30)	8.63 (219.07)	.06 (1.58)	1.50 (38.10)	.13 x 45° (3.17 x 45°)	16.88 (428.62)	16 @ 22.5°	.875-9	1.50 (38.10)	3.63 (92.07)	4 @ 90°
1250	10.25 (260.35)	23.000/22.997 (584.20/584.12)	19.50 (495.30)	10.13 (257.30)	10.65 (270.51)	.06 (1.58)	2.16 (54.86)	.13 x 45° (3.17 x 45°)	20.00 (508.00)	12 @ 30°	1.000-8	2.16 (54.86)	1.00 (25.40)	4 @ 90°
1300	10.25 (260.35)	25.750/25.747 (654.06/653.97)	21.00 (533.40)	9.97 (253.24)	11.65 (295.91)	.22 (5.59)	2.16 (54.86)	.13 x 45° (3.17 x 45°)	22.00 (558.80)	12 @ 30°	1.250-7	2.16 (54.86)	1.00 (25.40)	4 @ 90°
1375	11.00 (279.40)	28.125/28.122 (714.37/714.30)	23.50 (596.90)	9.98 (253.49)	13.45 (341.63)	.43 (10.92)	2.16 (54.86)	.13 x 45° (3.17 x 45°)	24.38 (619.12)	12 @ 30°	1.250-7	2.16 (54.86)	1.00 (25.40)	4 @ 90°
2000	15.25 (387.40)	35.75 (908.05)	35.75 (908.05)	15.62 (396.75)	—	—	4.24 (107.70)	.13 x 45° (3.17 x 45°)	32.25 (819.15)	18 @ 20°	1.250-7	2.00 (50.80)	1.00 (25.40)	4 @ 90°
2400	14.68 (372.87)	36.00 (914.40)	36.00 (914.40)	15.50 (393.70)	—	—	4.42 (112.27)	.13 x 45° (3.17 x 45°)	30.00 (762.00)	18 @ 20°	1.250-7	2.00 (50.80)	1.00 (25.40)	6 @ 60°
3500	18.00 (457.20)	44.50 (1130.30)	37.75 (958.85)	15.50 (393.70)	24.75 (628.65)	1.25 (31.75)	2.38 (60.45)	.19 x 45° (4.75 x 45°)	40.00 (1016.00)	30 @ 12°	1.531* (388.89*)	3.00 (76.20)	1.13 (28.70)	6 @ 60°
5000	18.00 (457.20)	44.50 (1130.30)	37.75 (958.85)	15.50 (393.70)	24.75 (628.65)	1.25 (31.75)	2.38 (60.45)	.19 x 45° (4.75 x 45°)	40.00 (1016.00)	30 @ 12°	1.531* (38.89*)	3.00 (76.20)	1.13 (28.70)	6 @ 60°

* Drilled hole only.